

Ford Mustang

PSU-300MTG Sound System Upgrade

Installation Manual

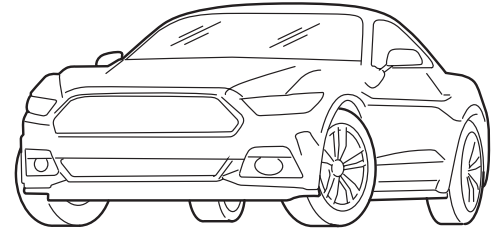

- Model: Mustang
- Model Year: 2015 – UP

*Not compatible with factory amplified systems

Ford	Model	Year
	Mustang	2015 – UP

* The specified vehicles have been tested and have met compatibility specs at the time of testing. Compatibility is not guaranteed if the manufacturer has made production changes to the listed vehicles above.

⚠ Warning: Before you begin, remove the ground wire from the NEGATIVE (-) terminal of the battery. Failing to do so can lead to electric shock, injury or damage to equipment.

Introduction

- Congratulations on purchasing the PSU-300MTG. This installation manual is designed to take you through the step-by-step installation of the PSU-300MTG into a 2015 - UP Ford Mustang. Please familiarize yourself with the owner's manual and if you still have additional questions please call 1-800-TECH-101.



Note

- Design and specifications are subject to change without notice for improvement.





To Ensure Safe Use, Always Follow These Precautions

- The installation of this product requires specialized skills and experience. We recommend that you have the product installed by an Alpine authorized dealer.
- Before you use this product, be sure to carefully read this installation manual and the separate user's manual so that you can use the product correctly. Alpine Electronics bears no responsibility for problems that arise as a result of failure to follow the instructions in the manuals.
- This manual includes a number of symbols that are intended to help you use the product safely, to prevent harm to you and others, and to protect against damage to property. These symbols and their meanings are listed below. Make sure you fully understand these symbols before you begin reading the main text.

Explanations of Injury and Damage That May Result from Incorrect Use

 Warning	Ignoring the content marked by this indication and using the product incorrectly may lead to death or serious injury.
 Caution	Ignoring the content marked by this indication and using the product incorrectly may lead to injury or property damage.

Types of Precautions

 Forbidden	Indicates actions that are forbidden (must not be performed)
 Forbidden	Indicates that disassembly is forbidden.
 Mandatory	Indicates actions that are mandatory (must be performed)
	Marks content that should receive your full attention.

 **Warning**

Do not disassemble or modify the product. Doing so could lead to an accident, fire, or electric shock.  Forbidden

Store screws and other small objects where small children cannot reach them. If one of these small objects is swallowed, consult with a doctor immediately. 

When replacing fuses, be sure to use fuses with the specified current rating. Failing to do so could lead to an accident or fire.   Forbidden Mandatory

Only connect the product to a 12 VDC negative ground car. Failing to do so could lead to an accident or fire.  Mandatory

Before you begin wiring, remove the ground wire from the negative terminal of the battery. Failing to do so could lead to electric shock or injury. 

Do not cut the insulation on a cord and take power from another device. Doing so could lead to fire or electric shock.  Forbidden

Do not install the product in a location where it will obstruct the driver's forward view; interfere with the operation of the steering wheel, gearshift, or the like; or pose a threat to passengers. Doing so could lead to an accident or injury.  Forbidden

When making a hole in the vehicle body, be careful to avoid damaging pipes, the fuel tank, electrical wiring, and the like. This kind of damage could lead to an accident or fire. 

When installing and grounding the product, do not use any of the bolts or nuts of the steering wheel, brakes, fuel tank, or the like. Doing so could make the brakes stop working or lead to fire.  Forbidden

Do not install the product near the passenger-side airbag. Doing so could interfere with the operation of the airbag and lead to an accident or injury.  Forbidden

Bundle cords so that they don't interfere with driving. Wrapping cords around the steering wheel, gearshift, brake pedal, or the like, could lead to an accident or damage equipment. 

 **Caution**

Connect the product properly according to the instructions. Failing to do so could lead to fire or an accident.  Forbidden

Do not sandwich cords between the seat railing or allow them to touch protrusions. Resulting breaks or shorts could lead to electric shock or fire. 





Do not block vents or heat sinks. Doing so could lead to fire or damage equipment. 

Use the accessories according to the instructions, and attach them securely. Failing to do so could lead to an accident or damage equipment.  Forbidden

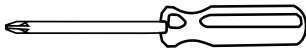

Do not install the product where it may be exposed to water or in a place with high levels of humidity or dust. Doing so could lead to fire or damage equipment.  Forbidden

The installation and wiring of this product requires specialized skills and experience. Have the product installed by an Alpine authorized dealer. 

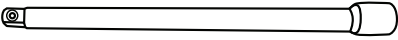
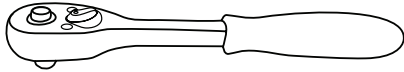
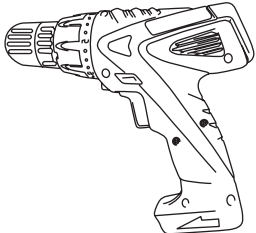
Tools Required

Panel Removal Tool	Sockets	Phillips Screwdriver
	 7mm 10mm	
Wire Cutters	Extension	Ratchet
		
	Cordless Power Drill	
		

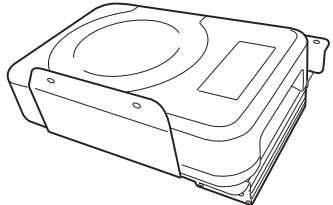
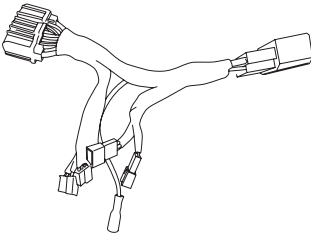
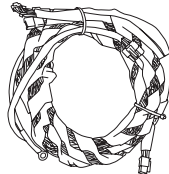
Accessory List

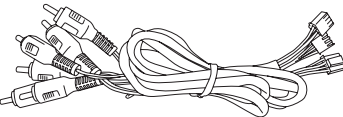
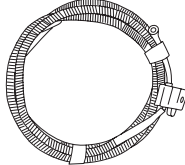
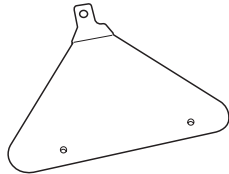
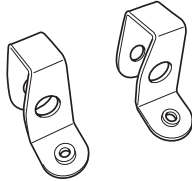
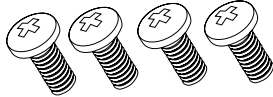
Amplifier Assembly	T-Harness	Main Harness
		
(10) Cable Ties	RCA Adapters	Power Cable
		
Mounting plate	Mounting Clips	(4) 8-32 Phillips Screws
		

Battery Terminal Removal

- 1 Loosen three clips by turning right on the battery cover and remove it.

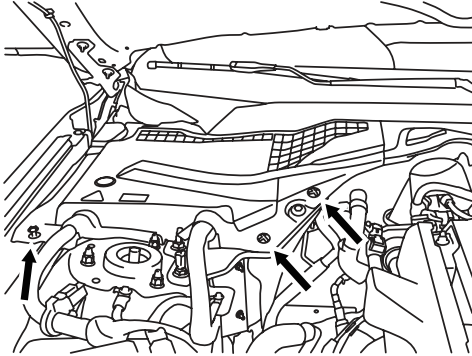

- 2 Use a 10mm socket to loosen the Negative (-) battery terminal and disconnect it.

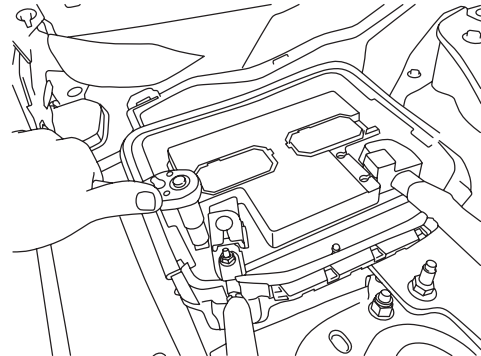

Radio Removal Process

- 1 Remove the vent panel above the radio by releasing the clips with a panel removal tool and pulling towards the back of the vehicle.

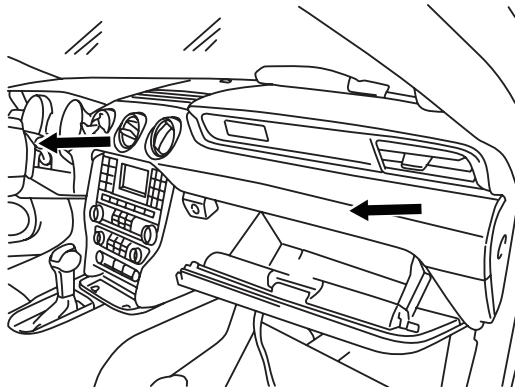

- 2 Remove the rubber cover from the tray in front of the shifter to reveal (2) 7mm screws and extract them.

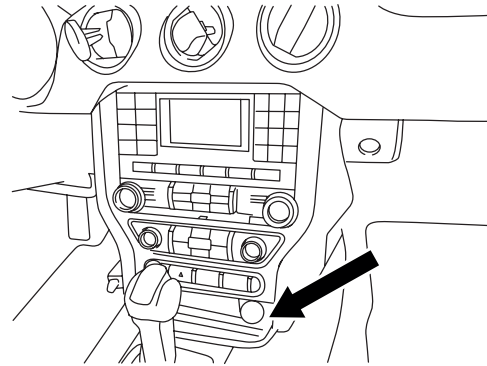

- 3 Use a panel removal tool to release and remove the plastic tray. Note: 2015 - 2017 models only. 2018 - Up skip to next step.

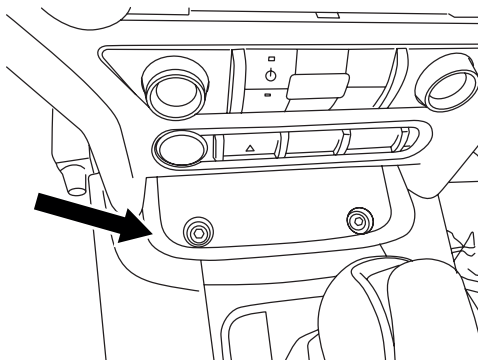

- 4 Remove the plastic cover between the USB port and the cigarette lighter.

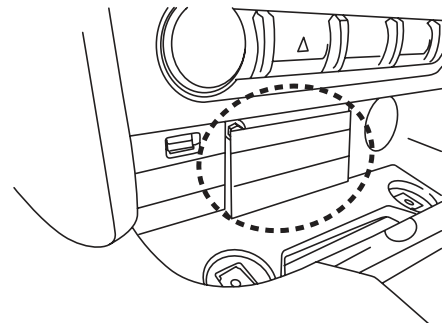

Radio Removal Process (continued)

- 5 Extract (4) 7mm screws and remove the radio panel. 6 Extract (4) 7mm screws and remove the radio.

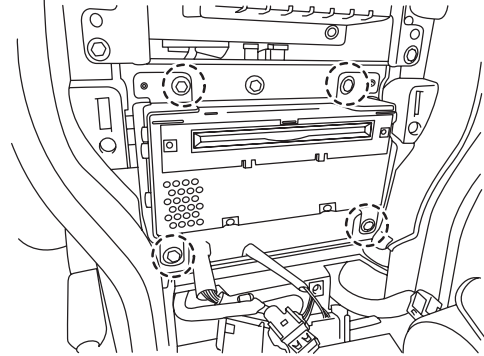
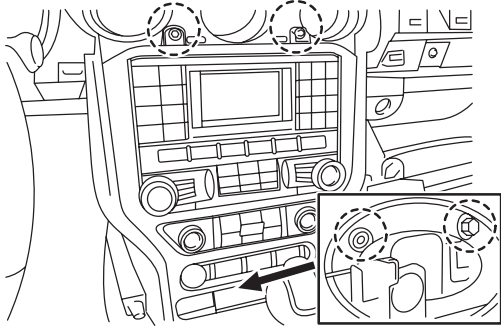

Kick Panel Removal Process

- 1 Use a panel removal tool to release the passenger side door sill and remove it. 2 Remove the passenger side kick panel by carefully lifting up.

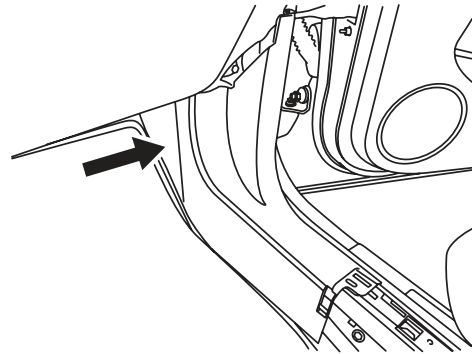
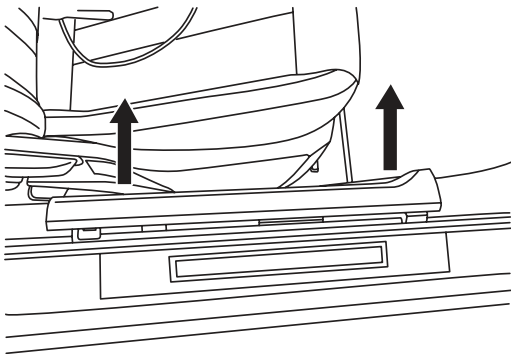

Installation

- 1 Connect the power cable to the **Positive (+)** battery terminal and route it through the passenger side firewall. **Note: The negative terminal should remain disconnected until the installation is completed.**
- 2 Route the power cable through the rubber grommet on the firewall on the passenger side foot well.

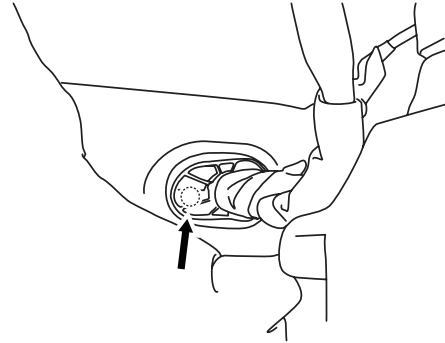
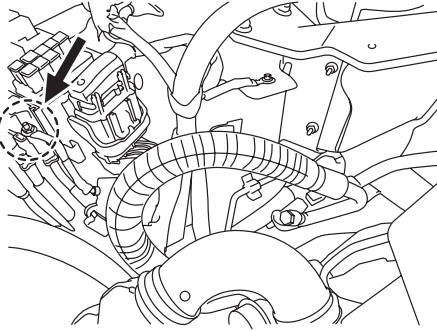

- 3 Locate (2) hole openings below the globe box and enlarge them to 1/2" using a step drill.

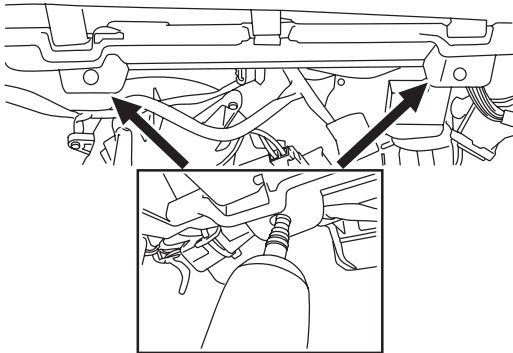

- 4 Release the globe box compartment by pressing the side tabs towards each other and releasing the shock on the right side.

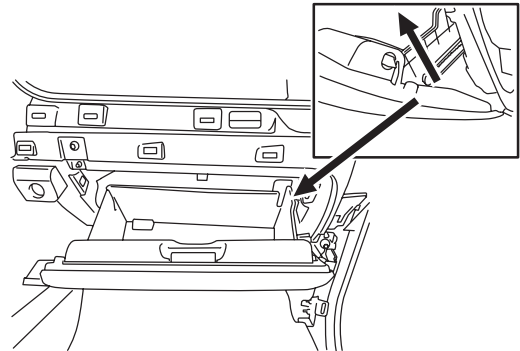

- 5 Remove (2) 8mm screws from the lower glove box compartment cavity and attach the (2) hook mounting clips using the same screws.

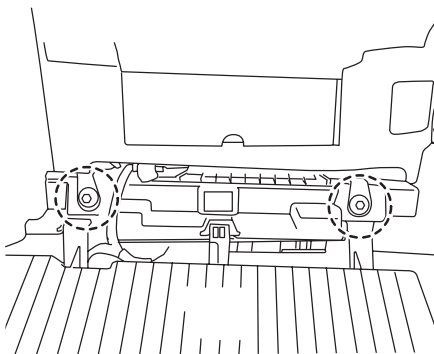

- 6 In some cases the clips may need to be opened slightly to allow sliding into place.

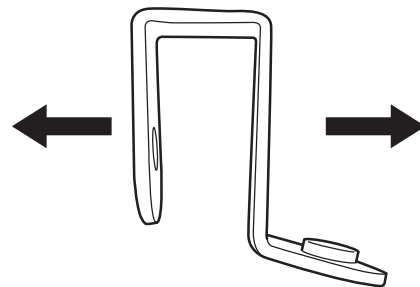

Installation (continued)

- 7 Mount the subwoofer level remote on the driver's side of the center console and route the cable to the passenger side foot well.

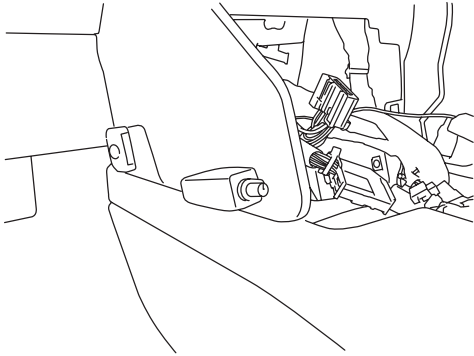

- 8 Use a 10mm socket to mount the firewall bracket to the factory stud below the fan assembly. **Note: Additional adjustment may be required (right to left) to mount the amplifier assembly.**

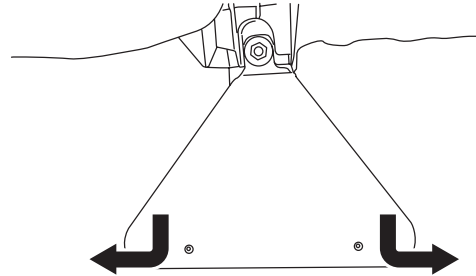

- 9 Connect the power cable to the main harness and attach the **Negative (-)** ground cable to the chassis stud on the kick panel.

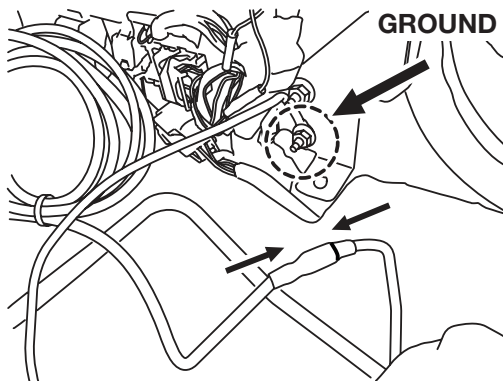

- 10 Roll and secure the excess cabling using the provided cable ties.

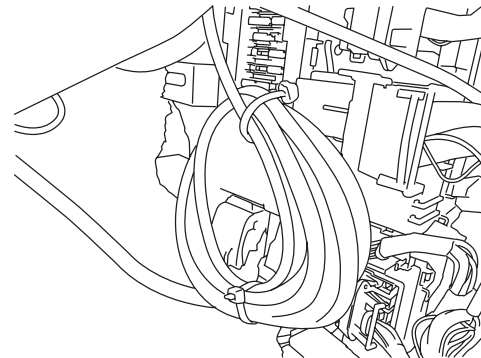

- 11 Connect the main harness and subwoofer level remote to the amplifier assembly.

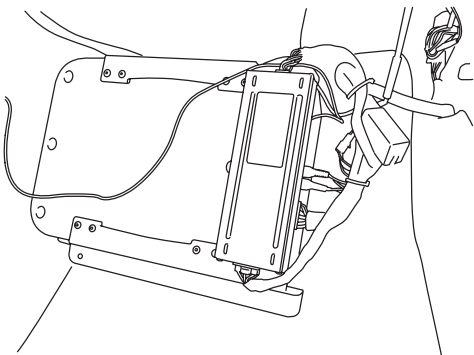

- 12 Route the main harness to the radio location and secure any excess wiring with the provided cable ties.

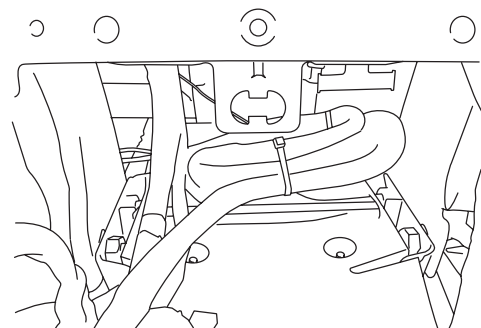

Installation (continued)

- 13** Make all necessary connections at the radio cavity based on your system configuration following the corresponding wiring diagram on pages 9, 10 or 11.

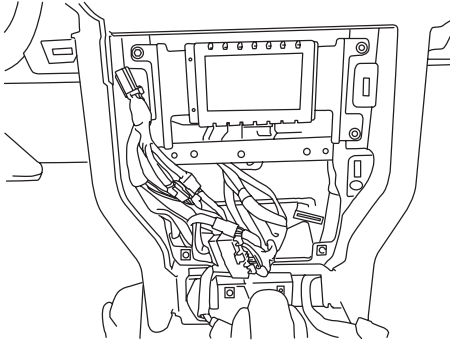

- 14** Mount the amplifier assembly using the provide 8-32" Phillips screws.

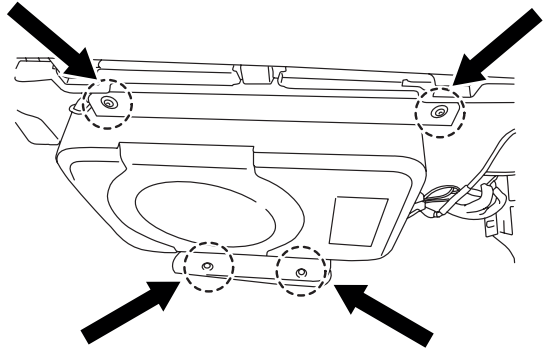

- 15** Replace all removed components to their corresponding location and connect the Negative (-) battery terminal.

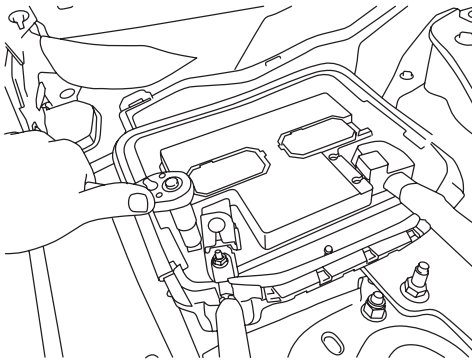

Disabling Active Noise Canceling

Note: Skipping this step will cause the subwoofer to emit unwanted engine rumble.

- 1** Remove the C-Pillars by pulling towards each other. Gently pull down the headliner to access the ANC microphone.
- 2** Disconnect the ANC microphone and replace all removed components to their corresponding location.

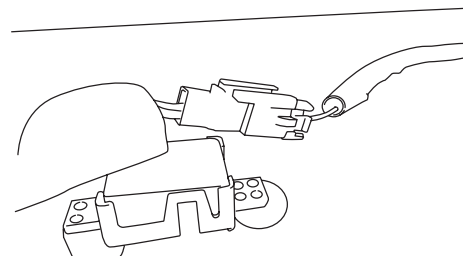
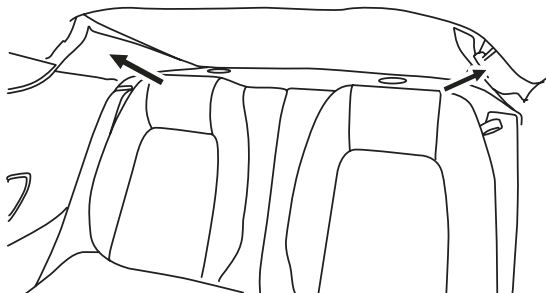

OEM Head Unit Wiring Diagram

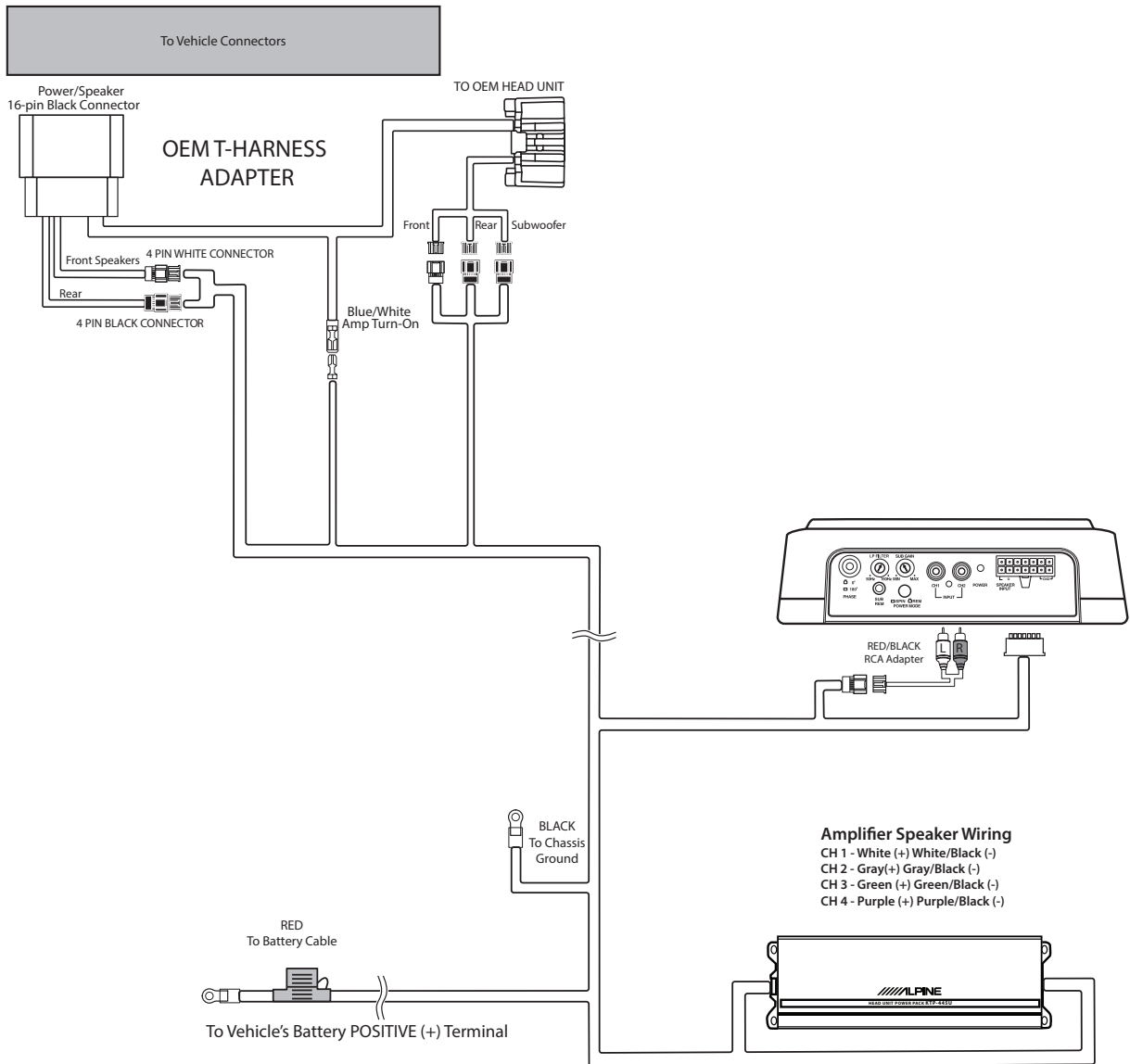

POWER PACK AMPLIFIER KTP-445U

↑ ↑ ↑ ↑ ↓ ↓

1 2 3 4 5 6

FRONT GAIN REAR GAIN

SUBWOOFER PWE-S8

LP FILTER SUB GAIN

50Hz 150Hz MIN MAX

PHASE SUB REM

0° 180°

SPIN REM POWER MODE

NOTE: FOR BEST PERFORMANCE SET AMPLIFIER AND SUBWOOFER TO RECOMMENDED SETTINGS AS SHOWN ABOVE

Aftermarket Head Unit Wiring Diagram

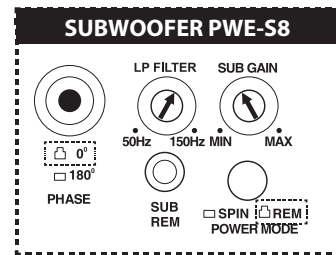
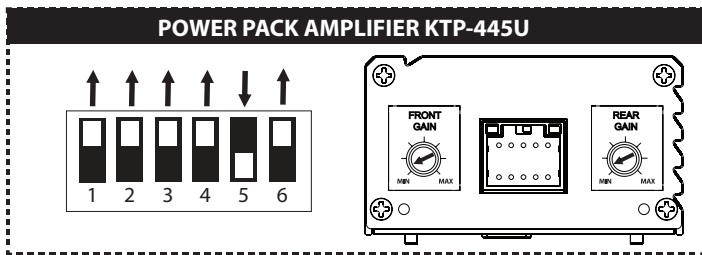
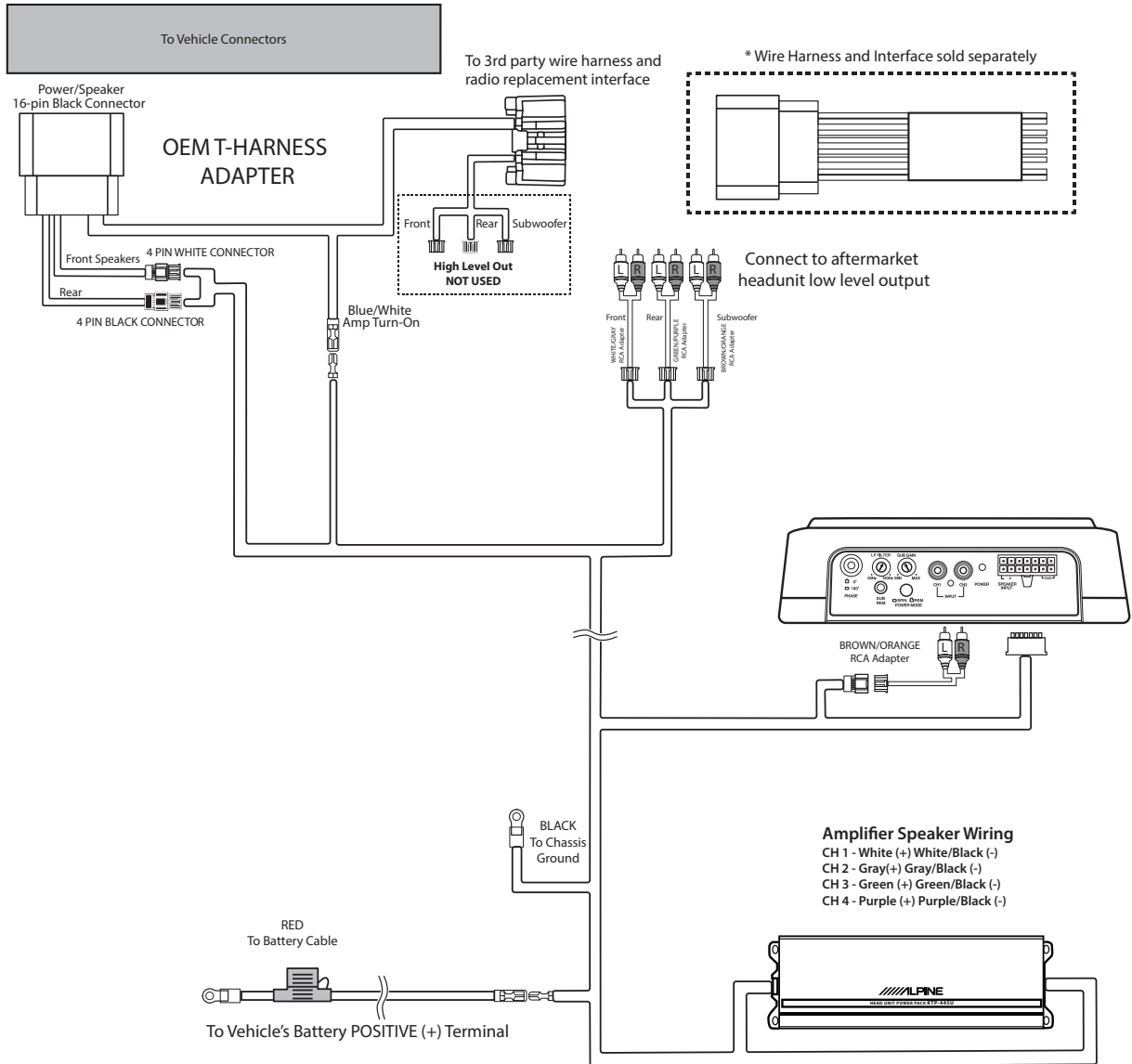

NOTE: FOR BEST PERFORMANCE SET AMPLIFIER AND SUBWOOFER TO RECOMMENDED SETTINGS AS SHOWN ABOVE

Alpine Restyle Head Unit Wiring Diagram

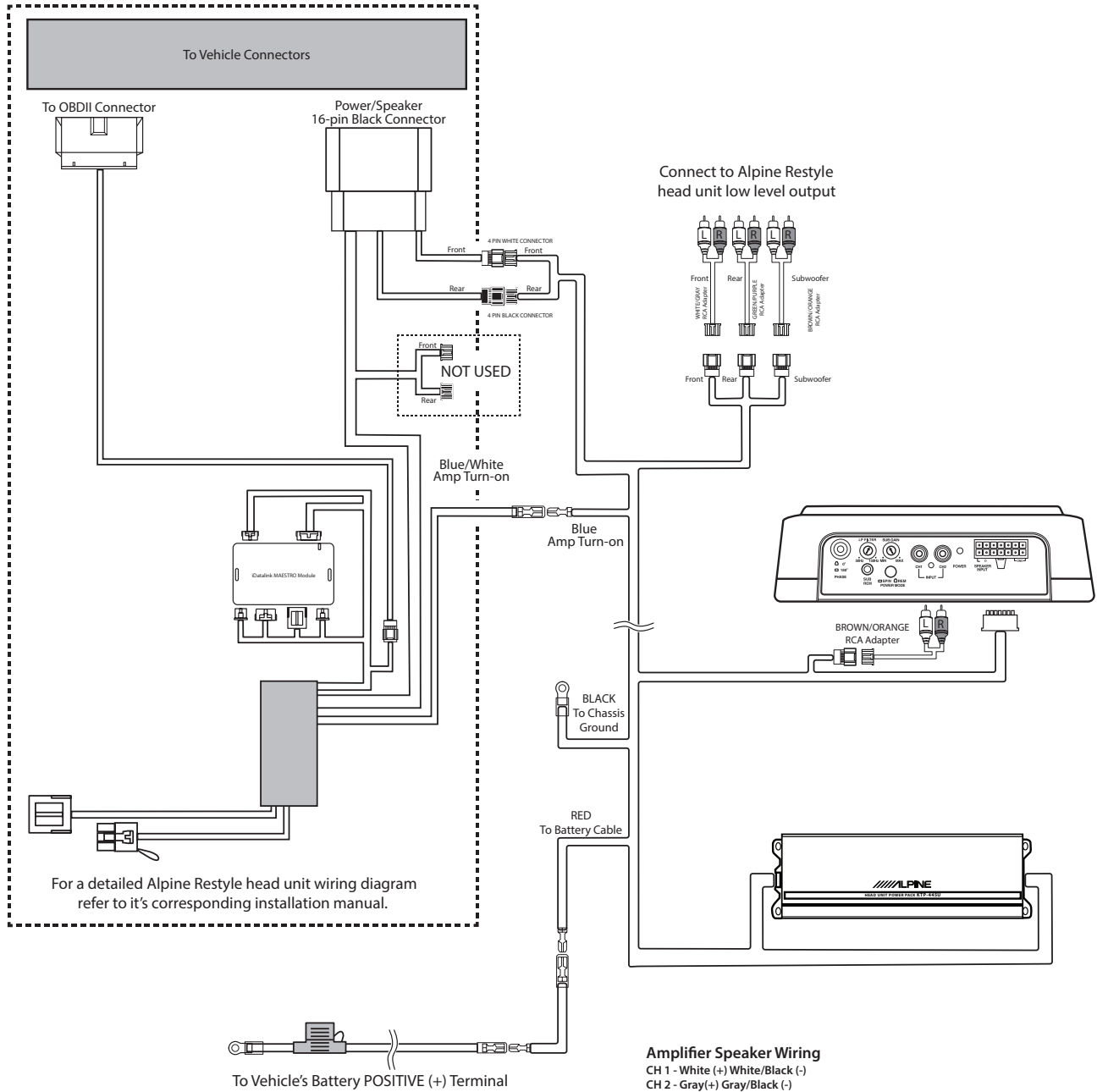

POWER PACK AMPLIFIER KTP-445U

FRONT GAIN (MIN/MAX) | REAR GAIN (MIN/MAX)

SUBWOOFER PWE-S8

LP FILTER (50Hz, 150Hz, MIN, MAX) | SUB GAIN (MIN, MAX)

PHASE (0°, 180°) | SUB REM | SPIN | REM | POWER MODE

NOTE: FOR BEST PERFORMANCE SET AMPLIFIER AND SUBWOOFER TO RECOMMENDED SETTINGS AS SHOWN ABOVE

Troubleshooting Guide

Symptom	Possible Cause	Remedy
1 System will not turn on	Missing or blown fuse at the battery	Insert or replace fuse
	Radio's Remote Turn-On wire may be disconnected.	Verify that Remote Turn-On wire is connected.
2 Volume is too loud with aftermarket headunit.	Speaker level out is connected at the T-Harness.	Ensure that the low level RCA adapters are used in aftermarket headunit system (refer to the corresponding wiring diagram).
	Amplifiers gain control has not been properly adjusted.	Refer to the corresponding system diagram.
3 Subwoofer sounds very low.	Gain level may be down to the lowest setting.	Adjust level to recommended setting (refer to the corresponding wiring diagram).
	Audio Phase may be reversed.	Ensure that the PHASE is set to 0°.
4 One of the speakers has no sound.	Disconnected pin or loose connection.	Check all connections to the speaker, loose pins, disconnected terminals etc..
5 Airbag light is on	Failed to disconnect the battery while working on the vehicle.	Disconnect the battery and re-connect after 5 minutes. If problem is not solved, the vehicle will have to be taken to a Ford dealer.
6 System turns on only on radio source	Aftermarket Power Antenna wire is connected to amp	Connect the Remote Turn-On wire (Blue/White) to the Blue wire on the amplifier harness.