

# REAR SPOILER, MUSTANG 2005 +

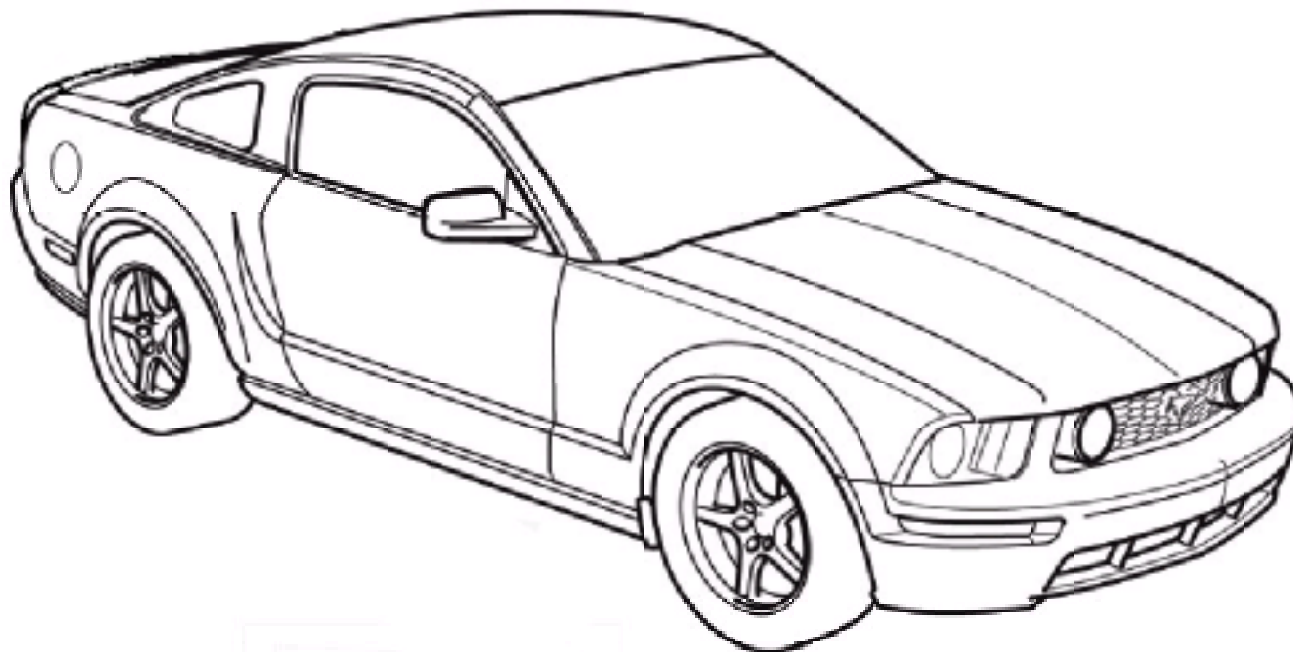

## 3-PIECE REAR SPOILER

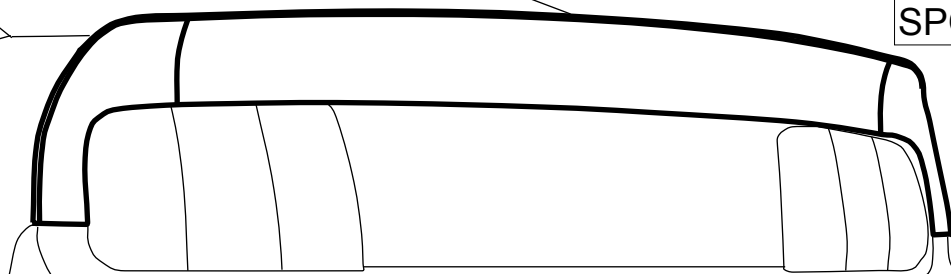

### KIT CONTENTS:

1. Spoiler (3 piece)
2. Template set (2 piece)
3. Thread-forming Screws (6)
4. Flange nuts (4)
5. Rust proofing packet
6. 1/2" Plastic plugs (4)

### TOOLS REQUIRED:

1. Car washing supplies
2. Masking tape
3. Drop cloth
4. Hammer
5. Center punch
6. Variable speed drill
7. 7/16" Socket wrench with extension
8. 3/16" Allen wrench
9. 1/8", 5/16" and 1/2" Drill bits  
or
- (9). #3 and #10 Unibits
10. Rubbing (Isopropyl) alcohol

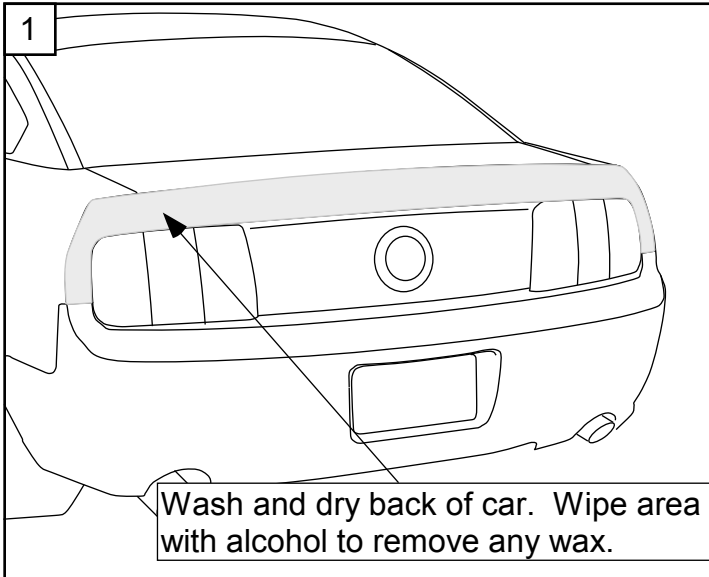

1  
Wash and dry back of car. Wipe area with alcohol to remove any wax.

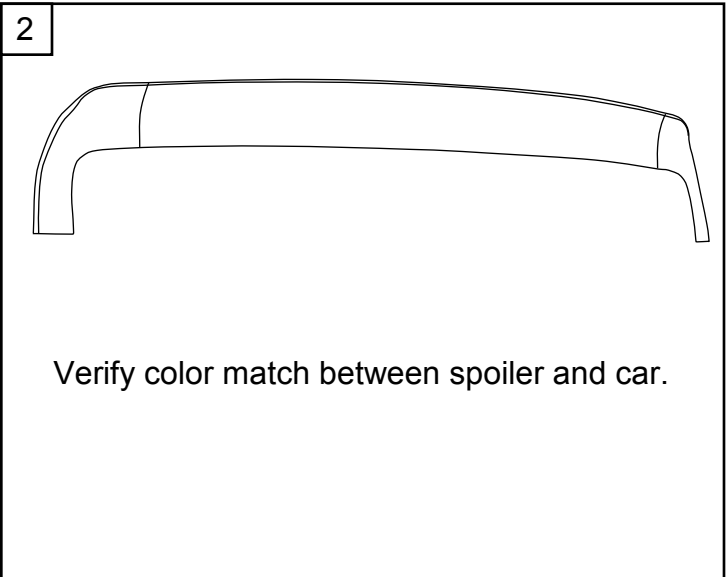

2  
Verify color match between spoiler and car.

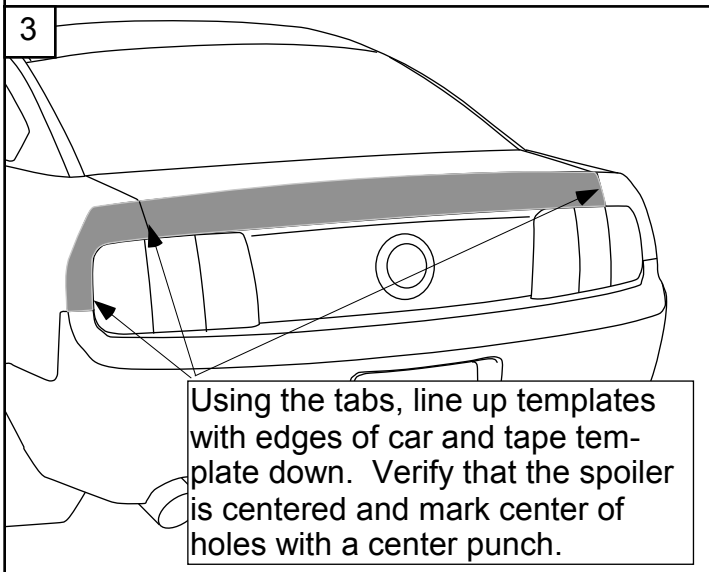

3  
Using the tabs, line up templates with edges of car and tape template down. Verify that the spoiler is centered and mark center of holes with a center punch.

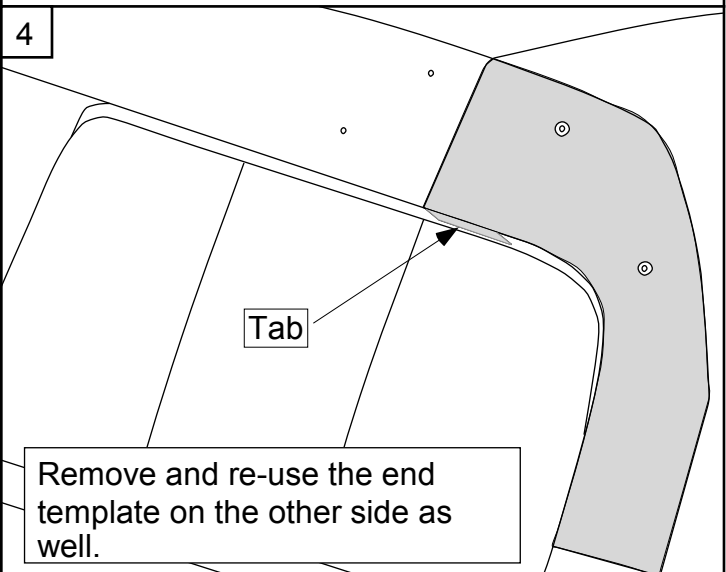

4  
Remove and re-use the end template on the other side as well.

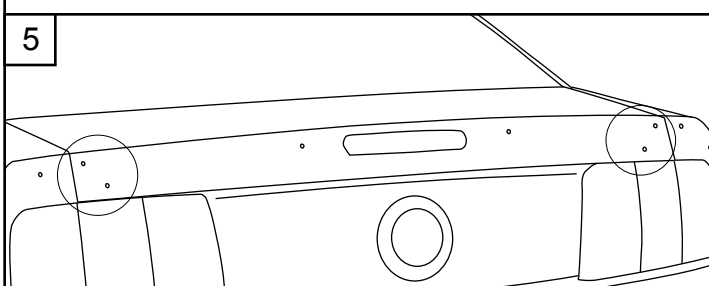

5  
Lay a drop cloth in the trunk and drill 1/8" pilot holes at the marks. On the four holes shown as circled open the trunk lid and continue to drill pilot holes through the inner skin of the trunk lid. It is important for the drill bit to be perpendicular to the trunk lid outer skin to correctly locate the inner skin access holes. Drill all the outer skin holes out with a 5/16" drill bit or a #3 Unibit.

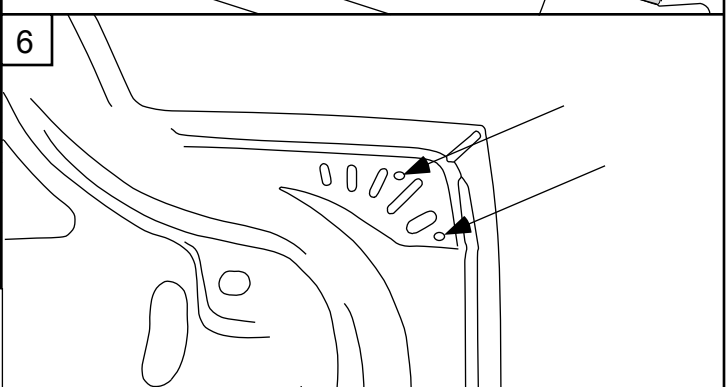

6  
The Access holes on the inner skin need to be drilled with either a 1/2" drill bit or a #10 Unibit. It is important to drill the holes on a flat surface so that the plastic plugs (step 15) will lay flat. Deburr and rust proof all holes.

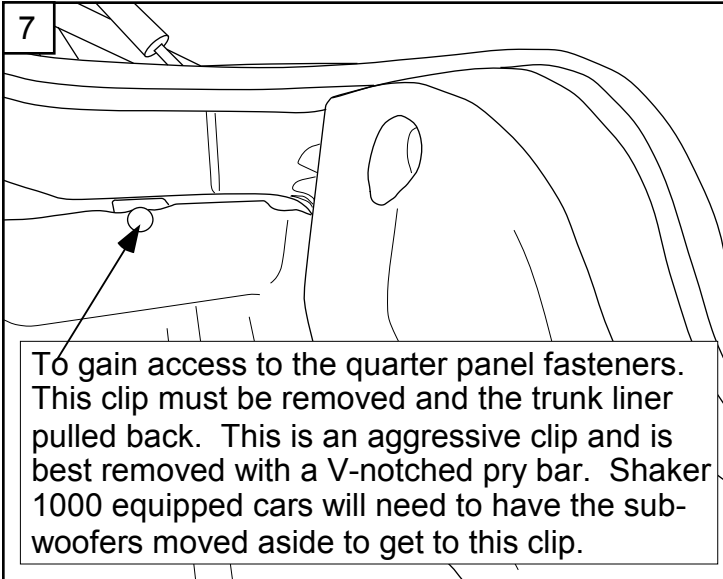

7  
To gain access to the quarter panel fasteners. This clip must be removed and the trunk liner pulled back. This is an aggressive clip and is best removed with a V-notched pry bar. Shaker 1000 equipped cars will need to have the subwoofers moved aside to get to this clip.

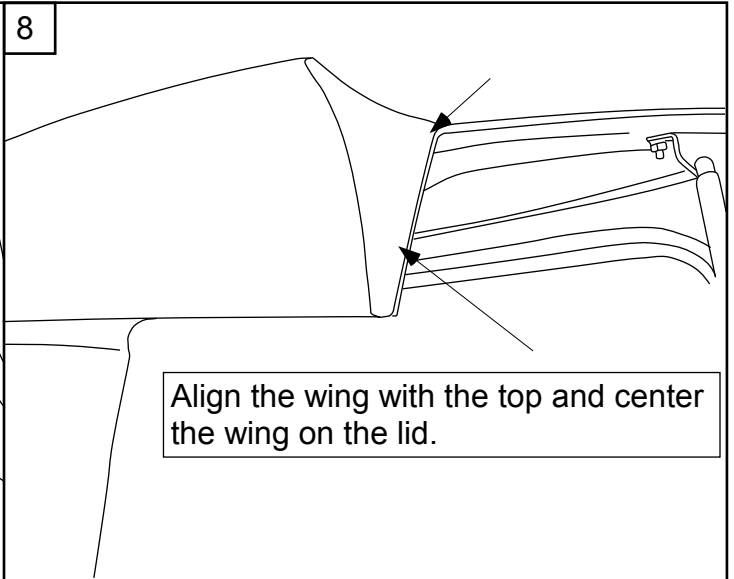

8  
Align the wing with the top and center the wing on the lid.

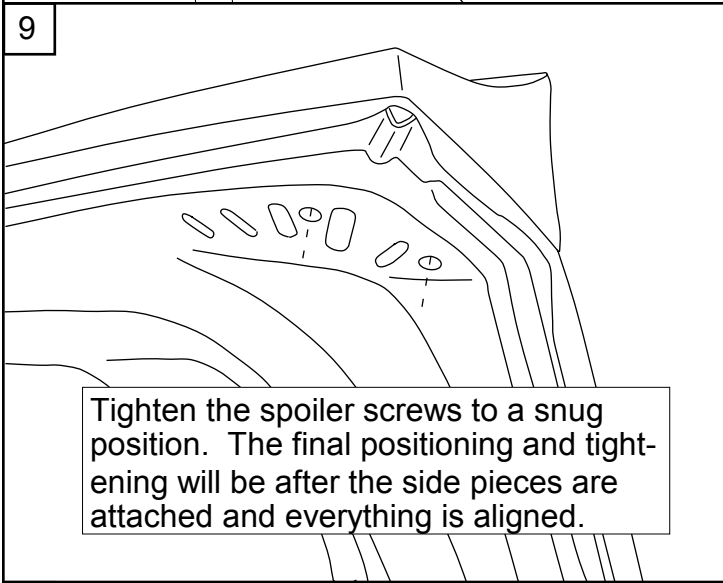

9  
Tighten the spoiler screws to a snug position. The final positioning and tightening will be after the side pieces are attached and everything is aligned.

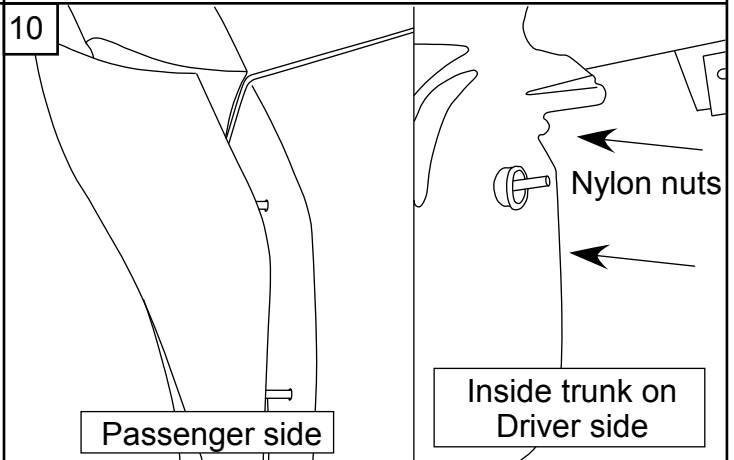

10  
Carefully guide studs through holes. The studs will be accessed by reaching beside the tail light. Snug up nuts with a socket wrench.

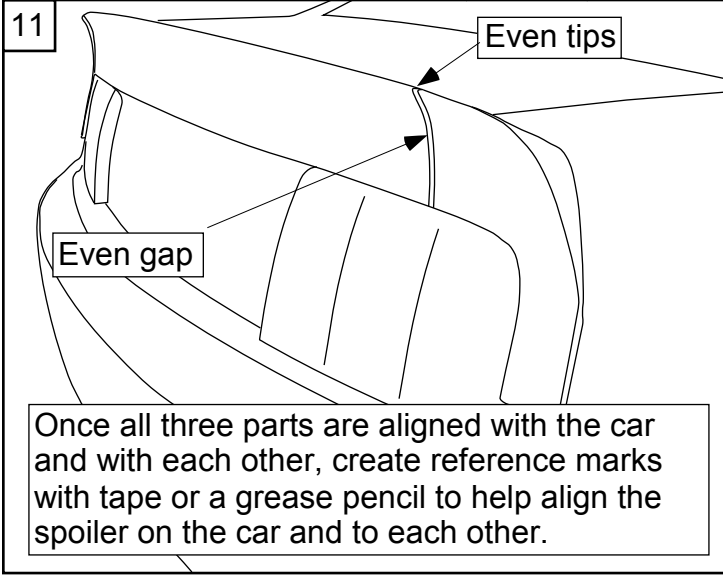

11  
Once all three parts are aligned with the car and with each other, create reference marks with tape or a grease pencil to help align the spoiler on the car and to each other.

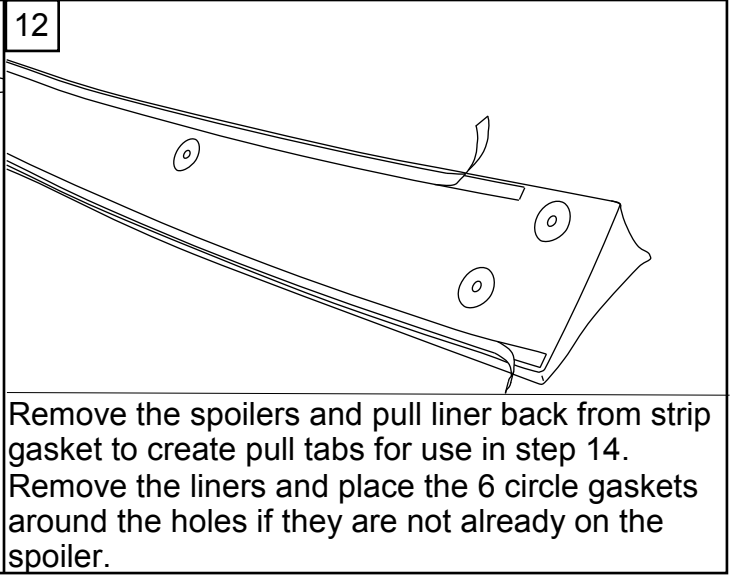

12  
Remove the spoilers and pull liner back from strip gasket to create pull tabs for use in step 14. Remove the liners and place the 6 circle gaskets around the holes if they are not already on the spoiler.

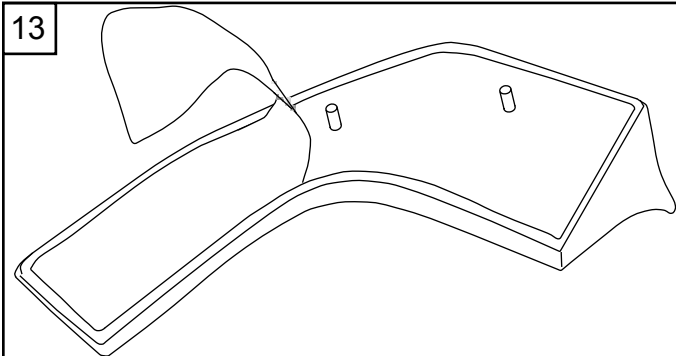

13  
Remove the back liners and place the gasket on each of the side pieces. Peel the front liner back past the studs to create a pull tab for step 14. The adhesive for the gasket below the lower stud will still be covered with the gasket liner to aid in positioning.

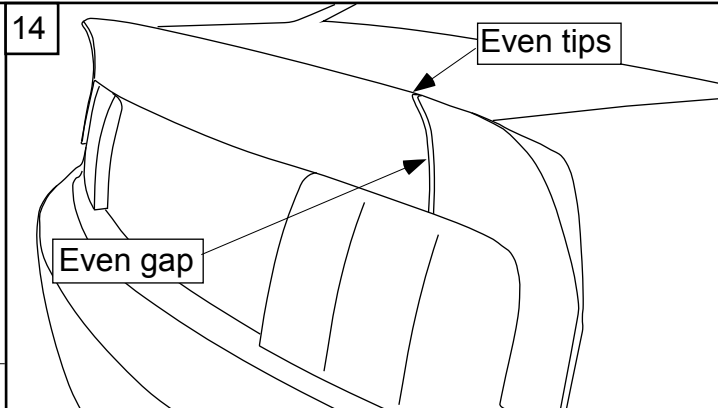

14  
Re-install the part onto the car using the reference marks as a guide. Once aligned, remove the gasket liners by pulling the tabs. Be careful not to shift the parts.

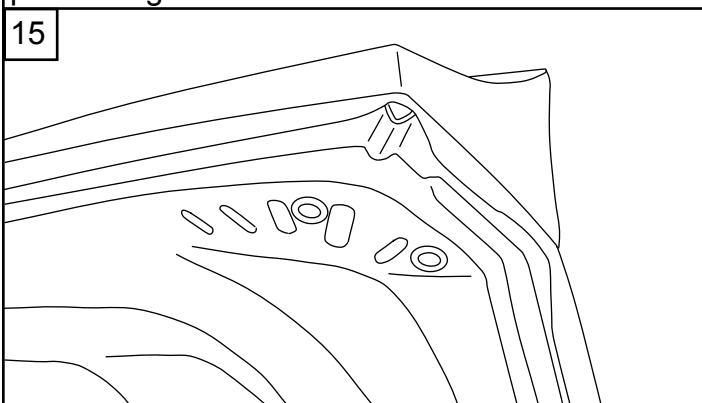

15  
Tighten the six thread forming screws (center wing) and four nuts (two each, side wings). Plug the trunk lid access holes with the provided plastic plugs.

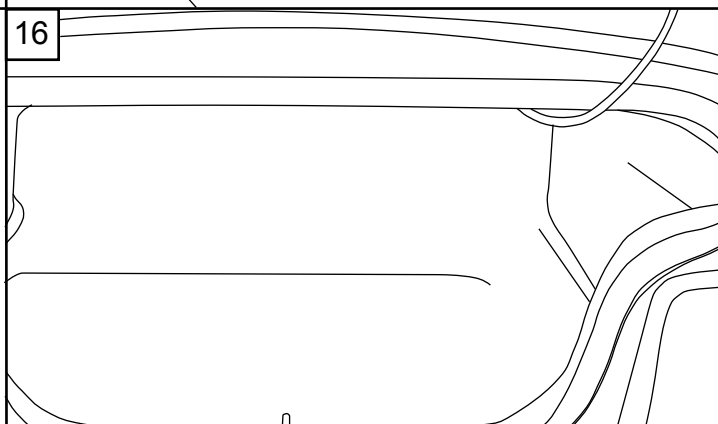

16  
Remove drop cloth and vacuum all metal shavings from the trunk floor and inner structure of trunk lid.

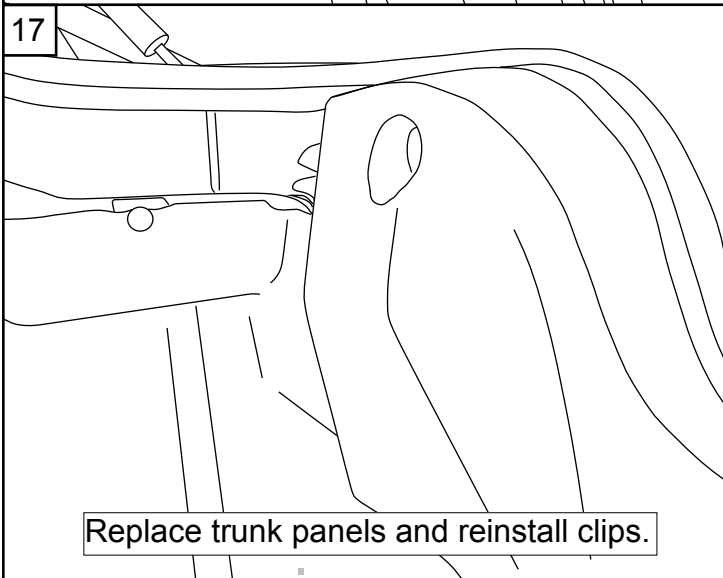

17  
Replace trunk panels and reinstall clips.

Note: When installation is complete the factory deck lid brake light must be unplugged.