



STEEDA

Billet Lower Control Arms

Installation Instructions For Kits

555-4405 and 555-4405PL

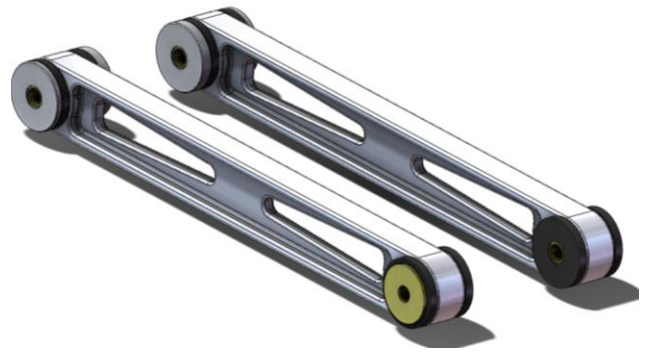

Note: Refer to a service manual for bolt torque specifications.

If you are not comfortable with replacing the factory control arms have a qualified technician perform the work.

Removal of the Factory Lower Control Arms

NOTE: Perform the following procedure one wheel at a time. Do NOT remove both lower control arms at the same time!

1. Raise the vehicle by supporting it on a lift or stand so that the rear suspension is loaded (wheels in contact with surface).
2. Chock the front wheels. Release the parking brake, if applied.
3. Remove the rear emergency brake cable from the caliper. Feed the cable back through the control arm.
4. Remove the stock front and rear lower control arm bolts.
5. Remove the lower control arm. It may need to gently pry out of position.

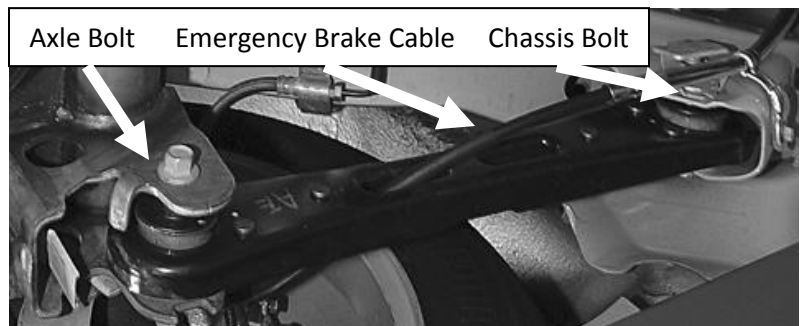

Installation of the Steeda Billet Lower Control Arms

6. Grease the outside faces of ALL the bushings with the supplied grease.
Note: Do not skip this step or the bushings may squeak while driving.
7. Install the control arms with the thicker aluminum spacer being placed on the inside (towards the center of the car) at the axle end. The thin aluminum spacer goes on the outside (towards the exterior of the car) at the axle end. If applicable, the Steeda logo should face towards the outside of the car.
8. Install the supplied Gold STEEL washer to the outside (towards the exterior of the car) at the chassis mount.
9. Reinstall the factory bolts and tighten to factory specs.
10. Reinstall the emergency brake cable and Zip-tie it to the control arm to secure it.
11. You are done! Road test the vehicle and listen for any squeaks or noises. If any are evident re-check torque on all fasteners.

