

---

---

## Notes

The contents of this document are subject to change without prior notice. No part of or this entire document may be reproduced in any form without prior written permission of Snow Performance, Inc under the copyright except for private use.

The names, addresses and telephone numbers mentioned are current as of January 1, 2010. Note that this information is subject to change. Please refer to [www.snowperformance.net](http://www.snowperformance.net) for current information.

# **INSTALLATION INSTRUCTIONS FOR PART #20001 FORCED INDUCTION BOOST COOLER® WATER / METHANOL INJECTION SYSTEMS**



---

---

## CONTENTS

---

<b>Kit Contents</b>	<b>3</b>
<b>Installation – Mechanical</b>	<b>4</b>
<b>Installation – Electrical</b>	<b>11</b>
<b>Testing the System</b>	<b>12</b>
<b>Tuning Quick Reference/Maintenance</b>	<b>13</b>
<b>Fluid Level Switch</b>	<b>15</b>
<b>Solenoid Upgrade (Optional)</b>	<b>16</b>
<b>Install Notes</b>	<b>17</b>
<b>Warranty/Disclaimer</b>	<b>18</b>

## Have a question?

FAQ: [www.snowperformance.net/faqs.php](http://www.snowperformance.net/faqs.php)

**CAUTION**

You must completely read through these instructions before installing and operating this product. Failure to do so can result in damage to this product and the vehicle.

---

---

## LIMITATION OF LIABILITY

REPAIR OR REPLACEMENT OF A DEFECTIVE PRODUCT IS THE ORIGINAL RETAIL PURCHASER'S EXCLUSIVE REMEDY UNDER THIS WARRANTY. DAMAGE OR INJURY TO THE ORIGINAL RETAIL PURCHASER, TO HIS OR HER VEHICLE, CARGO, OR PROPERTY, AND/OR TO ANY OTHER PERSON OR PROPERTY IS NOT COVERED BY THIS WARRANTY.

THIS WARRANTY IS EXPRESSLY MADE IN LIEU OF ANY AND ALL OTHER EXPRESS WARRANTIES, WHETHER ORAL OR WRITTEN. SNOW'S SOLE LIABILITY IS LIMITED TO THE REMEDY SET FORTH ABOVE. IN NO EVENT WILL SNOW BE LIABLE FOR ANY DIRECT, INDIRECT, CONSEQUENTIAL, INCIDENTAL, SPECIAL, EXEMPLARY, OR PUNITIVE DAMAGES OR FOR ANY OTHER DAMAGES OF ANY KIND OR NATURE (INCLUDING, BUT NOT LIMITED TO, LOST PROFITS OR LOST SALES). SOME STATES DO NOT ALLOW THE EXCLUSION OR LIMITATION OF INCIDENTAL OR CONSEQUENTIAL DAMAGES, SO THE ABOVE LIMITATIONS MAY NOT APPLY TO YOU.

### Non-Warranty Repair/Retest

Products returned due to damage or misuse and Products retested with no problem found are subject to repair/retest charges. Product will be returned to customer at customer's expense. A credit card number must be provided in order to obtain an RMA (Return Merchandise Authorization) number prior to returning Product.

## Contact Us:

### Phone

Office	(719) 633-3811
Fax	(719) 633-3496
Tech Support Line (Toll Free)	(866) 365-2762

### Web

<http://www.snowperformance.net>

### Email

[sales@snowperformance.net](mailto:sales@snowperformance.net)  
[customerservice@snowperformance.net](mailto:customerservice@snowperformance.net)  
[tech@snowperformance.net](mailto:tech@snowperformance.net)

### Mail

Snow Performance, Inc  
1017-A East Highway 24  
Woodland Park, CO 80863

---

---

Snow Performance, Inc. warrants that the Product shall conform to and perform in accordance with published technical specifications and shall be free of defects in materials and workmanship for 90-days providing:

1. You are the original purchaser and provide proof of purchase.
2. For 1-year warranty, the Warranty Card that came with system (not applicable to separate parts purchases) is returned to Snow within 45-days of purchase. If valid warranty card not on file with Snow, the standard 90 day warranty applies from date of purchase.
3. For Lifetime warranty, , the Warranty Card that came with system (not applicable to separate parts purchases) is returned to Snow within 45-days of purchase and Boost Juice® injection fluid is used exclusively.\*
3. An RMA # has been attained and is displayed on package containing returned part.
4. Parts Warranty ~ 90 day warranty on parts purchased separately if used in conjunction with a Snow System. No warranty implied if used with a non-Snow part/system.

Subject to Snow's inspection of the product, Snow will remedy defects in materials and/or workmanship by repairing or replacing, at Snow's option, the defective product without charge for parts or labor, subject to the limitations and exclusions described in this warranty.

This warranty does not cover problems caused by normal wear and tear including aesthetic oxidation of surfaces, accidents, unlawful vehicle operation, or modifications or repairs to product not performed or authorized by Snow. This includes any product that is disassembled or taken apart for any reason.

\* Boost Juice® usage evidenced by invoices/ receipts.

In addition, this warranty does not cover problems resulting from conditions beyond Snow's control including, but not limited to, theft, misuse, overloading, or failure to assemble, mount or use the product in accordance with Snow's written instructions or guidelines included with the product or made available to the original retail purchaser. In the event of failure, Snow will repair or replace the part at Snow's sole discretion. Failures resulting from misapplication or misuse of the Product, failure to adhere to any specifications or instructions, or failure resulting from neglect, abuse, accidents, or act of nature are not covered under this warranty.

Warranty service may be obtained by calling 719-633-3811, getting an RMA (Return Merchandise Authorization), delivering the part to Snow along with proof of purchase. Customer agrees to insure the Product or assume the risk of loss or damage in transit, to prepay shipping charges to Snow, and to use the original shipping container or equivalent. Shipping for Warranty replacement parts shipped outside the continental US will be charged to customer.

Non-Warranty Repair/Retest

Products returned due to damage or misuse and Products retested with no problem found will be returned to customer at customer's expense.

## Parts

- UHO (Ultra High Output) Pump
- 3 Qt Reservoir
- 10 ft High Pressure Tubing
- 3ft Black Wire Loom
- 18" 1/8" Silicone Tubing

## Electrical Packet

- 1 Fuse Holder
- 1 20AMP Fuse
- 1 Green LED w/Resistor
- 2 Blue Butt Connectors
- 1 Large Eyehook
- 2 Small Eyehooks
- 1 Male Connector
- 1 Female Connectors
- 1 Relay w/ Harness
- 10 Tie Wraps
- 1 Pressure Switch
- 1 Vacuum "T"

## Required Tools:

- Electric Drill W/ Drill Bits
- Adjustable Wrench
- Utility Knife
- Screw Driver
- 5/16 Open End Wrench
- 1/8" -27 NPT Tap

## Mechanical Packets

- 1 Nozzle Holder
- 1 Reservoir Fitting 3/8" NPT to 1/4" tube
- 8 #8x1&1/2" Screws
- 8 #8 Washers
- 4 #6x1/2" Screws
- 1 E-6000® (GOOP)

## Nozzles

- 60ML/MN (1)
- 100ML/MN (2)
- 175ML/MN (3)
- 225ML/MN (4)
- 375ML/MN (5)
- 625ML/MN (6)

## Upgrades

- Bulkhead
- 2.5 Gallon Reservoir
- Solenoid
- Hose Adaptor or Bung
- Nitrobooster®
- Dual Nozzle
- Carburetor Plate
- Boost Juice
- Level Switch

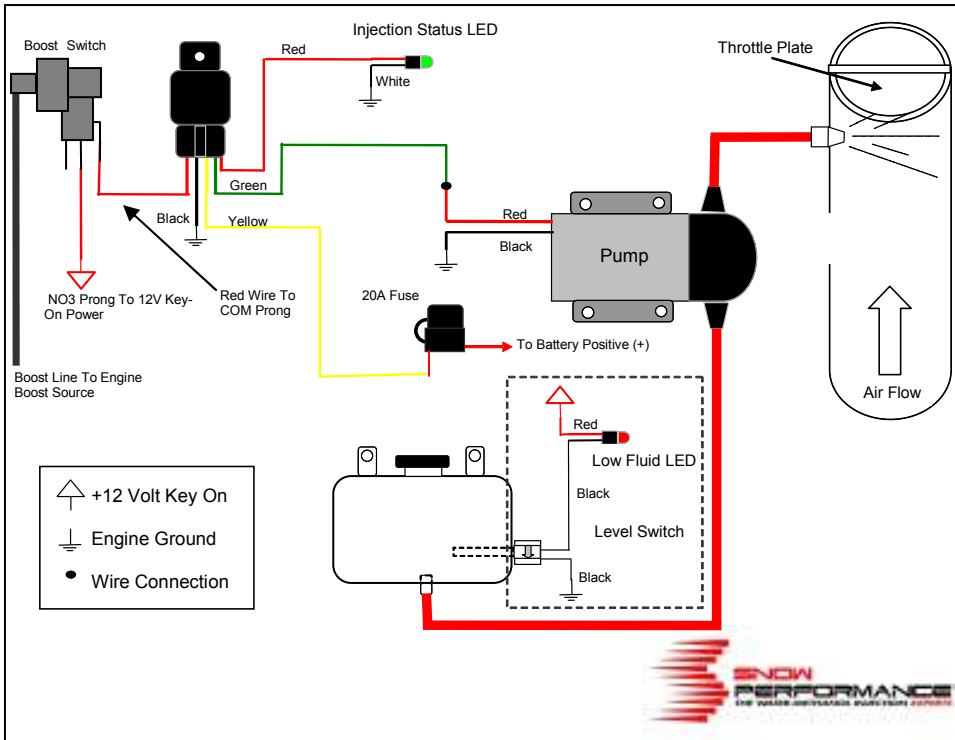

The boost switch has three prongs. The prong labeled "NO3" is for 12V key-on power, and the prong labeled "COM" connects to the relay's red wire. Note that there are two red wires on the relay harness. The red wire immediately next to the green wire is for the LED indicator light. The red wire with its own dedicated terminal connects to the boost switch which in turn connects to 12V key-on power.

## Nozzle Identification Chart:

Nozzle Number	Nozzle Size	Nozzle Number	Nozzle Size
1	60 ml/min	4	225 ml/min
2	100 ml/min	5	375 ml/min
3	175 ml/min	6	625 ml/min

## Installation- Mechanical

### Step 1 Reservoir Install

## Install Notes:

Pump Setting \_\_\_\_\_ (psig)

Nozzle Size \_\_\_\_\_ (ml/min)

Boost / Vacuum setting \_\_\_\_\_

## Disclaimer

Do not use this product until you have carefully read the following agreement. This sets forth the terms and conditions for the use of this product. The installation of this product indicates that the BUYER has read and understands this agreement and accepts its terms and conditions. Performance products by their nature are designed to increase horsepower and performance not engineered in the original vehicle and the increased stress could result in damage to related systems. This is a high performance product – use at your own risk. Snow Performance Inc., Its agents, employees or owners shall not be under any liability whether in contract or otherwise whether or not resulting from our negligence or contents of information supplied for any damage or loss resulting from such information. The BUYER is responsible to fully understand the capability and limitations of his/her vehicle according to manufacturer specifications and agrees to hold the SELLER harmless from any damage resulting from failure to adhere to such specifications. The SELLER disclaims any warranty and expressly disclaims any liability for personal injury or damages. The BUYER acknowledges and agrees that the disclaimer of any liability for personal injury is a material term for this agreement and the BUYER agrees to indemnify the SELLER and to hold the SELLER harmless from any claim related to the item of the equipment purchased. Under no circumstances will the SELLER be liable for any damages or expenses by reason of use or sale of any such equipment. The BUYER is responsible to obey all applicable federal, state, and local laws, statutes, and ordinances when operating his/her vehicle, and the BUYER agrees to hold SELLER harmless from any violation thereof. The SELLER assumes no liability regarding the improper installation or misapplication of its products. It is the installer's responsibility to check for proper installation and if in doubt, contact the manufacturer.

## Warranty

Warranty Policy

---

---

## Solenoid Upgrade (optional)

The optional Solenoid Upgrade (#40060) is required if the nozzle is to be installed after the intake throttle plate (as shown), or the fluid reservoir is mounted higher than the nozzle. It is highly recommended for trunk-mount reservoirs.

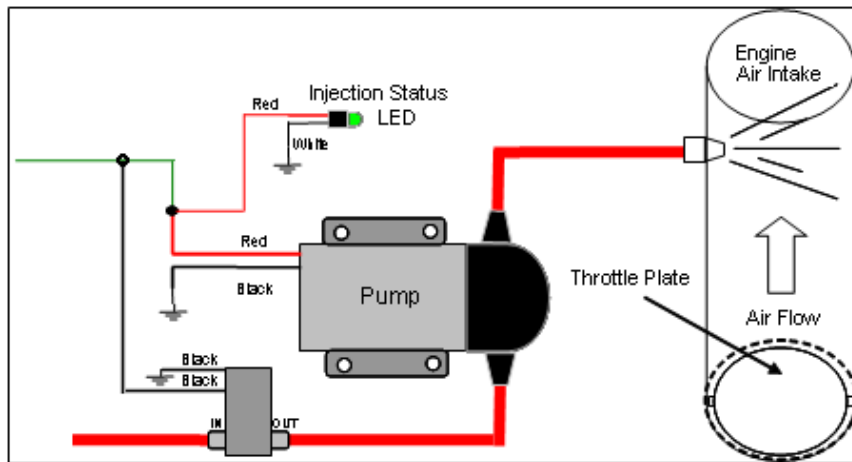

Finger thread the two 1/8" NPT quick connect fittings into ports labeled (2 or IN) and (1 or OUT) on the solenoid. Tighten an additional half turn past finger tight.

### Note: Solenoid must be installed Pre-pump to ensure correct operation.

Cut high pressure line at location solenoid is to be installed. Insert ends of cut line into quick connect fittings of solenoid. The port labeled (2 or IN) is the inlet and the port labeled (1 or OUT) is the outlet. Gently pull on line to check secure connection. If line pulls out, re-insert farther into fitting to engage locking clips. If high pressure line removal is required, firmly press in metal fitting ring to disengage locking clips while pulling hose from fitting.

Connect one of the BLACK wires from solenoid to the RED positive pump wire or the WHITE wire from the controller. Note that connecting the wire to any other power source other than the pump/controller wire will result in improper operation of solenoid. Connect the second BLACK wire to a secure chassis ground location.

---

---

Install 3/8" NPT to 1/4" tube reservoir fitting using E6000® sealant in the bottom of the reservoir.

The nozzle, not the reservoir, should be the highest point in the system.

**Optional:** The factory windshield washer reservoir can be used as the reservoir for your system, using optional part number 40080.

- Drill 9/16" hole in desired bulkhead location.
- Remove one nut from bulkhead and turn the remaining nut until it is at the very end.
- Feed red tubing through the drilled hole and up and out of the top of the reservoir.
- Attach tubing to the bulkhead on the side opposite the nut.
- Pull the tubing through the bulkhead hole until the bulkhead seats against the inside of the reservoir.
- Apply E6000® sealant (included) around bulkhead.
- Slide the nut you had previously removed up onto the tube and thread onto bulkhead.
- While pulling firmly on the red tubing, tighten the outer nut using a 17mm socket (only needs to be hand tight). A ratchet is not needed.
- Once sealant has set, fill reservoir with water and check for leaks.

---

## Caution\*\*\*\*\*

To avoid gravity feeding of fluid with rear mount reservoirs, it is essential to use a check valve in-line between the reservoir and pump. **Do not operate** your rear mount equipped vehicle without a check valve installed.

---

## Caution\*\*\*\*\*

Whenever the nozzle is mounted post-throttle plate, to avoid siphoning fluid at idle, it is essential to use a solenoid upgrade inline between the reservoir and pump.

---

## Step 2 Pump Install

Mount the pump so the inlet is positioned at the lowest point of the reservoir or lower. Pump can be mounted horizontally or vertically using the supplied screws and washers. Ensure that no sharp bends in the high pressure tube occur near the pump. Sharp bends can cause stress on the inlet and outlet ports of the pump, causing leaks. Trim tube with a utility knife or razor blade, making sure to eliminate any burrs or kinks on the end. Insert firmly into the pump about ½ inch through the light grey locking collar. Note the arrows indicating flow direction on the top of the pump. To remove the hose, gently and evenly push the light grey locking collar into the head unit of the pump, then pull on the hose gently.



Measure the distance from the reservoir outlet to the pump inlet. Cut the ¼" red tubing using utility knife. Make cuts are as square as possible.

Ensure there are no kinks in the tubing and insert tubing into quick disconnects at pump and reservoir until fully seated. Keep the pump within 2 feet of the reservoir.

## Fluid Level Switch (optional)

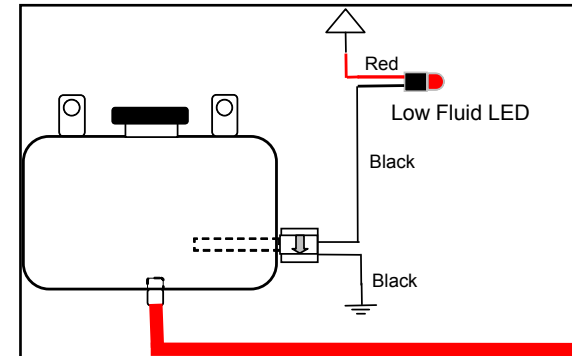

### Instructions

- Locate desired level switch mounting position. Suggested placement is 1/5 of max reservoir height.
- Carefully drill side of reservoir using 13/16" bit. A step bit is recommended for best drilling results. Hole must be free of nicks or shavings for proper sealing.
- Remove rubber seal from level switch. Insert seal into reservoir until fully seated. Goop can be used around the edges of the hole.
- Lubricate exterior of level switch with water and insert into seal until fully seated. Position level switch so **GT** symbol is at six o'clock position.
- Wait 30 minutes for Goop to cure, then test for leaks. With fluid level above level switch, float should be angled up. With fluid level below level switch, float should be in horizontal position.
- Connect one black wire from level switch to ground.
- Connect other black wire from level switch to white wire from LED.
- Connect red wire from LED to +12 volt key on power source.



---

---

minimize combustion quench, you should start with an air to fuel ratio of 12.0-12.5:1.

Injecting water/methanol lower than 3300-3500 RPM could result in combustion quench. All vehicles are different. If the engine bogs or loses power, then it is coming on too early, the quantity is too much, or there is not enough methanol in the mixture (50/50 water/methanol recommended).

---

## Caution\*\*\*\*\*

Prolonged quench may cause lower engine damage over a period of time.

---

**Maintenance** – Remove nozzle(s) and clean screen filters once per year using carb cleaner.

The Boost Cooler® has been designed to operate with high concentrations of methanol. Oil or other additives are not required for system lubrication, and can cause damage to the system.

Contaminants in the fluid such as dirt can damage the system. Ensure that dirt and debris do not fall into the tank.

Do not use Teflon tape or paste to seal connections. These sealers are not as effective as the Goop sealant provided and can break down over time, clogging components.

For best performance, cooling and system life it is recommend that Snow Performance Boost Juice™, part #40008, be the exclusive fluid used in the system.

---

---

## Caution\*\*\*\*\*

Pump must be shielded from road debris and tire wash. Failure to do so will result in pump failure

---

### Step 3 Nozzle Selection

Nozzle sizing is a function of horsepower, which approximates the engine airflow, and boost, which approximates intake charge heat.

Recommended starting points:

250 - 350 RWHP:	175 ml/min nozzle.
350 - 475 RWHP:	375 ml/min nozzle
475 - 600 RWHP	625 ml/min nozzle



**TECH TIP** Seal the nozzle into the nozzle holder using the included E6000® sealant. Using a sealant that is not permanent will allow for nozzle changes during tuning. Simply remove the nozzle, clean the threads, and reinstall using sealant.

Assemble desired nozzle into nozzle holder using E6000® sealant. **The end of the nozzle with the fine mesh screen is to be inserted into the nozzle holder.** Torque 1/2 turn past finger tight. Do not use Teflon sealants on Snow Performance fittings.



Correct



Incorrect

**NOTE:** If nozzle is mounted lower than the reservoir, a Solenoid Upgrade (#40060) must be used to prevent draining.

If pump goes on and fluid level doesn't go down, there is an obstruction in the tube or nozzle.

Activation of the pump in 1-5 second intervals will purge air from the system after install. This can be accomplished in initial use.

### Step 2 Test LED vs. Pump On

Apply a 12v source to pole #87 of relay (single red wire, not red/green wire). Pump should activate and LED should go on. Check LED ground and wiring if no activation. If wiring and ground check out okay, check LED with 12v source.

## Initial Tuning

### #20001 Set Boost Switch Activation Point

At the factory setting, the boost switch will start injection at about 10 psig boost. Adjusting the set screw clockwise will increase the boost pressure needed to activate injection. Turning the adjustment screw counter-clockwise will decrease it. 1 full turn counter-clockwise will decrease the injection point by 1-2 psig. Typical injection onset points are at 1/2 of maximum boost.



**TECH TIP** Introducing water/methanol before 1/2 of maximum boost pressure could result in quenched combustion and engine misfire.

## Tuning Quick Reference

The power potential of the system is realized through increased boost and/or timing. The large gains on octane and cooling provided by the system make this possible, even on standard pump fuel.

The Boost Cooler® adds an alternate fuel source as well as significantly cools combustion. With the Boost Cooler®, one does not need to cool combustion with overly rich air/fuel ratios. To



---

---

## Testing the System

**Note: for best results, prime pump before use to clear air from the pump and insure that the system is primed:**

- Fill reservoir with water approx ¼ full.
- Remove tubing from nozzle (or solenoid if solenoid used in-line between pump and nozzle) and run tube into separate container.
- Apply 12 VDC to red pump wire for approximately 5 seconds or until fluid flow is consistent.
- Pump is now primed. Reconnect tubing from pump outlet to nozzle (or solenoid).

**If using a check valve in between the pump and the reservoir:**

Remove the check valve and place a solid piece of tube between the pump and the reservoir and prime the system. Then replace the check valve in between the pump and reservoir.

### Step 1 Test Pump and Mechanical System

Turn key to ON position. Bypass the pressure switch by touching a wire between the two poles on the switch. Pump should activate, green LED should go on, and fluid level in tank should go down. It is recommended to also check the nozzle spray pattern while following this procedure. Also check for leaks.



---

---

### Step 4 Nozzle Mounting

The nozzle assembly should be installed 90° to the direction of airflow. On round intake tubes, this is 360° around the tube meaning the nozzle can be mounted in any direction. This will ensure maximum cooling as the nozzle sprays in a cone pattern. Be sure that the nozzle tip is flush with the inside wall of the tube, or even projecting into it slightly to ensure no interference in the spray pattern. Make sure the nozzle is the highest point in the system as well.

Drill and tap (11/32" pre-drill, 1/8"-27 NPT tap) air inlet tube as close as possible to throttle body/throttle plate.



The nozzle is mounted using its external 1/8 NPT threads. Tighten the nozzle and nozzle holder assembly one half turn past finger tight using E6000® to seal the threads.

Carb Plates are available for 4150 and 4500 style carburetors.

You can mount the nozzle in a plastic or rubber air inlet tube using a Nozzle Mounting Adapter (#40110). Weld-in aluminum (#40120) and steel (#40130) bungs are also available.

**TECH TIP** The recommended nozzle mounting point is before the throttle body/ throttle plate. If you mount the nozzle after the throttle body/throttle plate (including use of a carb spacer plate) or below the reservoir, a Solenoid Upgrade (#40060) must be used to prevent siphoning at idle or gravity feed.

---

---

## Step 5 Nozzle Connection

Measure the distance from the pump outlet to the nozzle holder. Cut the ¼" tubing using utility knife. Make cuts are as square as possible.

Ensure there are no kinks in the tubing and insert tubing into quick disconnects until fully seated. Gently pull on tubing to ensure a good connection.



**Optional Aluminum Bung Shown**

Use tie wraps to help route tubing and to ensure it doesn't contact moving or hot parts in the engine compartment. Have tubing connect to quick connect fittings at shallow angles. Having an immediate sharp bend may unseat the tubing from the internal o-ring and create a leak.

Continual insertion and removal from quick connect fittings will mar the end of the tubing. Over time the internal gripping teeth may lose their hold of the tubing which may create a leak. If this occurs simply remove the tubing and make a fresh cut using a razor blade.

---

---

## **Installation - Electrical**

### **Required tools**

- Drill
- Screw Driver – Cross Tip
- Wire Cutter/Stripper/Crimper
- Please refer to electrical diagram.

### Step 1 Pressure Switch

Mount the pressure switch using a tie wrap. Hard mounting using screws is not recommended as diaphragm distortion could cause the switch to malfunction.

Attach 1/8" silicone tubing (supplied) to hose barb on switch. Other end of the hose attaches to manifold boost source. Wire switch according to wiring diagram.

### Step 2 LED

Select location of LED (green-on when pump activated) in driver's compartment of vehicle. Run RED and BLACK wires to LED and make required connections as indicated in wiring diagram. Note that the RED wire immediately next to the GREEN wire is used for the LED, not the RED wire on the opposite side of the relay harness from the GREEN wire. The WHITE wire of the LED connects to ground, the RED wire of the LED connects to the proper RED wire.

### Step 3 Relay

Mount the relay on fire wall close to the pressure switch. Wire relay according to diagram using supplied connectors. Either of the combined GREEN/RED wires can be used to power the pump, injection status LED, or Solenoid Upgrade. The single RED wire is the switched activation input. It is typically connected to the adjustable pressure switch, but can also be connected to a nitrous solenoid or other 12V input to control injection.

**CAUTION: Do not route wires near hot or moving parts. Use corrugated wire loom and tie wraps (supplied) to protect and route wires.**