

## Lakewood Mustang Lower Control Arms (79-98) - Installation Instructions



The below installation instructions work for the following products:

- **Lakewood Mustang Lower Control Arms (79-98)**



Please read through the instructions carefully before starting this project. Take the time to get all the materials together as well as all the safety equipment.

### Warning:

Installation of these control arms requires working underneath vehicle. USE EXTREME CARE AND CAUTION WHEN WORKING UNDERNEATH VEHICLE. Never get near or under vehicle until you are confident that it is safely supported and will not move or fall from its raised position. DO NOT USE A BUMPER JACK.

### Preparation for Installation:

1. Place vehicle on a solid level surface to ensure safe installation
2. Place wheel blocks in front of and behind both front wheels to prevent movement in either direction.
3. Raise rear of vehicle and support flat area of chassis in front of lower control arm attaching point using approved automotive support stands having adequate load capacity. DO NOT put support stands under the axle housing. Note: Raise vehicle high enough to allow adequate clearance for coil spring removal.

### Control Arm Assembly:

1. Install grease fittings (supplied) into each end of control arm by driving fittings into drilled hole of bushing eyelet using a hammer and either a 9/32" or 7mm socket. Use care not to damage fittings (see illustration).

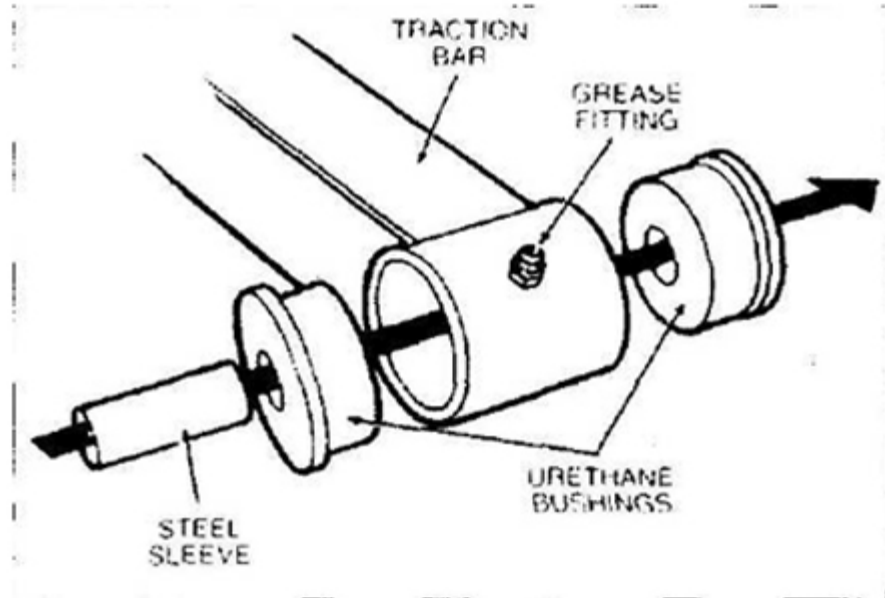

2. Apply lubricant (supplied) to polyurethane bushings and steel sleeves, then install into eyelet ends as shown.

#### Control Arm Install

1. We recommend working on only one side at a time. There is a right hand and left hand control arm. The correct arm for each side can be determined by the location of the stabilizer bar mounting plate and coil spring perch. The arms should be installed with the stabilizer mounting plate located toward the outside and the spring perch toward the rear.
2. Remove both rear wheels.
3. Apply penetrating oil or rust release lubricant to front and rear mounting bolts of lower control arms and stabilizer bar mounting bolts.
4. Remove stabilizer bar.
5. Drop exhaust system down far enough to allow access to front lower control arm bolts.
6. Raise axle housing up approximately 2" (a hydraulic floor jack is recommended for this procedure).
7. Using an 18mm hex wrench, remove nut from vertical shock absorber lower bracket mount stud. Compress shock slightly to facilitate removal of bracket stud from axle housing bracket.
8. Slowly lower axle housing until coil spring pressure has been removed and carefully remove spring.
9. Using an 18mm hex socket and wrench, remove lower control arm. DO NOT discard the bolts and nuts, they will be reused.
10. Determine the correct control arm for the side you are working on (the Lakewood Control Arm should be installed with the stabilizer mounting plate located toward the outside and the spring perch toward the rear). Install the control arm to the chassis and axle housing brackets using the stock factory mounting bolts and nuts previously removed.
11. Tighten front and rear control arm mounting bolts to 80 ft./ lb. torque
12. Place coil spring into position. Be sure to replace the factory rubber seats on the top and bottom of the spring.

13. Raise axle housing up to compress coil spring enough to allow re-attachment of the shock absorber. Replace factory hex nut onto bracket mount stud. Tighten securely.
14. Follow the same above procedure for installation of Lakewood Control Arm on other side of vehicle.
15. When both control arms are installed, re-attach the stabilizer bar using the stock factory mounting bolts and nuts. Tighten securely.
16. Lubricate both ends of the traction bars with good quality chassis grease.
17. Re-attach exhaust system and tighten all fasteners securely.
18. Install wheels and properly tighten lug nuts to wheel manufacturer's specifications.
19. Carefully remove support stands and lower vehicle to ground.
20. Periodically check to make sure that all mounting hardware is securely tightened. Use a good quality chassis grease to keep bushings and sleeves properly lubricated

Installation instructions provided by Lakewood

Find more **how-tos**, **instructions** and **videos** at [www.americanmuscle.com](http://www.americanmuscle.com)!